

Алматы (7273)495-231
Ангарск (3955)60-70-56
Архангельск (8182)63-90-72
Астрахань (8512)99-46-04
Барнаул (3852)73-04-60
Белгород (4722)40-23-64
Благовещенск (4162)22-76-07
Брянск (4832)59-03-52
Владивосток (423)249-28-31
Владикавказ (8672)28-90-48
Владимир (4922)49-43-18
Волгоград (844)278-03-48
Вологда (8172)26-41-59
Воронеж (473)204-51-73
Екатеринбург (343)384-55-89

Иваново (4932)77-34-06
Ижевск (3412)26-03-58
Иркутск (395)279-98-46
Казань (843)206-01-48
Калининград (4012)72-03-81
Калуга (4842)92-23-67
Кемерово (3842)65-04-62
Киров (8332)68-02-04
Коломна (4966)23-41-49
Кострома (4942)77-07-48
Краснодар (861)203-40-90
Красноярск (391)204-63-61
Курск (4712)77-13-04
Курган (3522)50-90-47
Липецк (4742)52-20-81

Магнитогорск (3519)55-03-13
Москва (495)268-04-70
Мурманск (8152)59-64-93
Набережные Челны (8552)20-53-41
Нижний Новгород (831)429-08-12
Новокузнецк (3843)20-46-81
Ноябрьск (3496)41-32-12
Новосибирск (383)227-86-73
Омск (3812)21-46-40
Орел (4862)44-53-42
Оренбург (3532)37-68-04
Пенза (8412)22-31-16
Петрозаводск (8142)55-98-37
Псков (8112)59-10-37

Пермь (342)205-81-47
Ростов-на-Дону (863)308-18-15
Рязань (4912)46-61-64
Самара (846)206-03-16
Саранск (8342)22-96-24
Санкт-Петербург (812)309-46-40
Саратов (845)249-38-78
Севастополь (8692)22-31-93
Симферополь (3652)67-13-56
Смоленск (4812)29-41-54
Сочи (862)225-72-31
Ставрополь (8652)20-65-13
Сургут (3462)77-98-35
Сыктывкар (8212)25-95-17
Тамбов (4752)50-40-97

Тверь (4822)63-31-35
Тольятти (8482)63-91-07
Томск (3822)98-41-53
Тула (4872)33-79-87
Тюмень (3452)66-21-18
Ульяновск (8422)24-23-59
Улан-Удэ (3012)59-97-51
Уфа (347)229-48-12
Хабаровск (4212)92-98-04
Чебоксары (8352)28-53-07
Челябинск (351)202-03-61
Череповец (8202)49-02-64
Чита (3022)38-34-83
Якутск (4112)23-90-97
Ярославль (4852)69-52-93

Россия +7(495)268-04-70

Казахстан +7(7172)727-132

Киргизия +996(312)96-26-47

www.solzaima.nt-rt.ru | | sax@nt-rt.ru

Технические характеристики на печи-камины pelletные с дополнительной трубной вентиляцией, со стеклянной дверцей K2 12 KW, FUJI 12 KW, PINE 12 KW, ASPEN 12 KW, Himalaia 12 KW компании **SOLZAIMA**

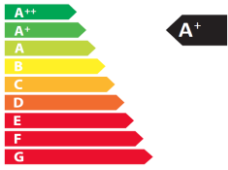
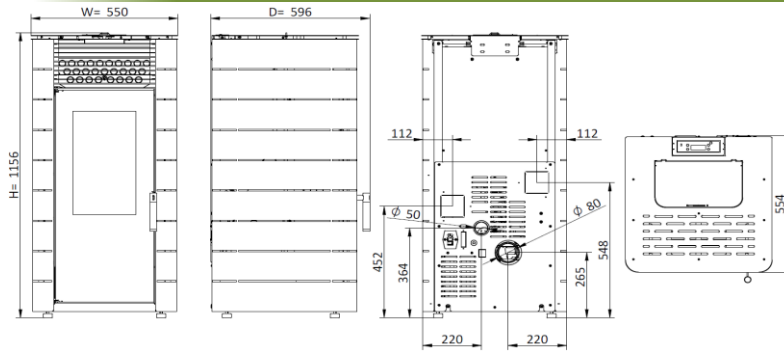
EEl 121
Características técnicas / Datos técnicos / Technical characteristics / Caractéristiques techniques / Dati Tecnici
NORMA: EN 14785
RELATÓRIO: CEE-0201/19-1



Potência red-nom / Potencia red-nom / Min-Nom output power / Puissance red-nom / Potenza red-nom	3,9 - 11,9	(kW)
Rendimento Pot.red-Pot.nom / Rendimiento Pot.red-Pot.nom / Efficiency Red.power-Nom.power / Rendement Pui.red-Pui.nom / Rendimento Pot.rid-Pot.nom	96 - 92	(%)
Potência água / Potencia agua / Water output power / Puissance eau / Potenza acqua	n/a	(kW)
Temp. Fumos min.-máx. / Temp. Humos min.-máx. / Smoke temp. min.-máx. / Temp. Fumées min.-máx. / Temp. Fumi min.-máx.	53 - 125	(°C)
Emissões CO(13%O2) min.-máx. / Emisiones CO(13%O2) min.-máx. / Emissions CO(13%O2) min.-máx. / Émissions CO(13%O2) min.-máx. / Emissioni CO(13%O2) min.-máx.	0,045 - 0,016	(%)
CO2 min.-máx.	7,3 - 9,4	(%)
Partículas-OCG-NOX (13%O2) / Partículas-OCG-NOX (13%O2) / Particles-OCG-NOX (13%O2) / Particules-OCG-NOX (13%O2) / Particolato-OCG-NOX (13%O2)	12 - 6 - 154	(mg/Nm3)
Tiragem recomendada (máx. potência) / Tiro recomendado (máx. potencia) / Recommended draw (máx. power) / Tirage conseillé (máx. puissance) / Tiraggio consigliato (máx. potenza)	12 ***	(Pa)
Caudal mássico / Masa de humos / Mass flow / Débit massique / Flusso di massa	9,2	(g/s)
Tensão / Tensión / Voltage / Tension / Tensione	230	(V)
Frequência / Frecuencia / Frequency / Fréquence / Frequenza	50	(Hz)
Potência elétrica nominal / Energía eléctrica nominal / Nominal electric power / Puissance électrique nominale / Energia elettrica nominal	167 (máx 362)	(W)
Consumo de pellets min.-máx. / Consumo de pellets min.-máx. / Pellet consumption min.-máx. / Consommation pellet min.-máx. / Consumo di pellet min.-máx.	0,9 - 2,7 **	(kg/h)
Capacidade do depósito / Capacidad del depósito / Tank capacity / Capacité du réservoir / Capacità serbatoio	30	(kg)
Autonomia à potência min.- máx. / Autonomia a la potencia min.-máx. / Autonomy to power min.-máx. / L'autonomie de puissance min.-máx. / L'autonomia di potenza min.máx.	33,3 - 11,1 **	(H)
Diâmetro da chaminé / Diámetro de chimenea / Flue pipe / Diamètre de cheminée / Diametro del camino	80	(mm)
Entrada de ar da combustão / Entrada de aire para la combustión / Combustion air inlet / Entrée air pour la combustion / Ingresso aria per la combustione	50	(mm)
Volume aquecimento / Volumen de calefacción / Heating volume / Volume de chauffage / Volume di riscaldamento	269 *	(m3)
Caudal ventilador / Flujo del ventilador / Fan flow / Flux ventilateur / Flusso della ventola (25 Pa)	415	(m3/h)
Tipo de combustível / Tipo combustible / Type of fuel / Type combustible / Tipo combustibile	Pellet (EN 14961-2 A1) diam. 6 mm/ L 10-30 mm	-
Peso líquido / Peso neto / Net weight / Poids net / Peso netto	143	(kg)
Peso com embalagem / Peso com embalaje / Weight with packaging / Poids avec emballage / Peso con imballo	164	(kg)
Dimensões com embalagem (LxHxP) / Dimensiones con embalaje / Dimensions with packing / Dimensions avec l'emballage / Dimensioni con imballaggio	990 x 1440 x 640	(mm)
Volume água / Volumen de agua / Water volume / Volume d'eau / Volume di acqua	n/a	(L)
Pressão máx. / Pressione máx. / Pressure máx. / Pression máx. / Pressione máx.	n/a	(bar)
Distância mínima a materiais combustíveis (laterais/frente/topo) / Minimum distance to combustible materials (side/front/top) / Distance minimale aux matériaux combustibles (côté/avant/haut) / Distanza minima da materiali combustibili (lato/antieriore/sotto)	200 / 1500 / 1000	(mm)
Comprimento máx. de lenha / Longitud max. Leña / Length max. Firewood / Longueur max. bois de chauffage / lunghezza max. legna	n/a	(mm)
Dimensão câmara de combustão (LxHxP) / Tamaño de la cámara de combustión / Combustion chamber size / Taille de la chambre de combustion / Dimensioni camera di combustione	276 x 415 x 170	(mm)
Nível sonoro ventilador - Ventilador auxiliar (máx.) / Nivel de sonido ventilador - Ventilador auxiliar (máx.) / Sound level fan - Auxiliary fan (máx.) / Niveau sonore ventilateur - Ventilateur auxiliaire (máx.) / Livello sonoro ventilatore - Ventola supplementare (máx.)	48 - 61	(dB)

Opções / Opciones / Options / Options / Opzioni
Conexão termostato WiFi / Conexión termostato Wi-Fi / Connection thermostat WiFi / Connexion thermostat WiFi / Collegamento termostato WiFi
Controlo Remoto / Control Remoto / Remote Control / Télécommande / Telecomando
Ventilador Auxiliar / Ventilador Auxiliar / Auxiliary fan / Ventilateur Auxiliaire / Ventola Supplementare
1x 135 m3/h (0 Pa) / 2x 135 m3/h (0 Pa)

* Valor que pode variar segundo o tipo de isolamento (Cálculo efectuado para 44 W/m3 ou 35 Kcal/h por m3) / El valor puede variar en función del tipo de aislamiento (El cálculo se realiza a 44 W/m3 o 35 Kcal/h per m3) / Value that could vary depending on the type of insulation (Calculation made to 44 W/m3 or 35 Kcal/h for m3) / La valeur peut varier en fonction du type d'isolation (Calcul fait à 44 W/m3 ou 35 Kcal/h per m3) / Il valore può variare a seconda del tipo di isolamento (Il calcolo fatto per 44 W/m3 o 35 Kcal/h per m3)

** Dados que podem variar segundo o tipo de pellet utilizado / Los datos pueden variar según el tipo de pellet utilizado / Data may vary according to the type of pellet used / Les données peuvent varier en fonction du type de pellets utilisé / Dati che possono variare a seconda del tipo di pellet usato

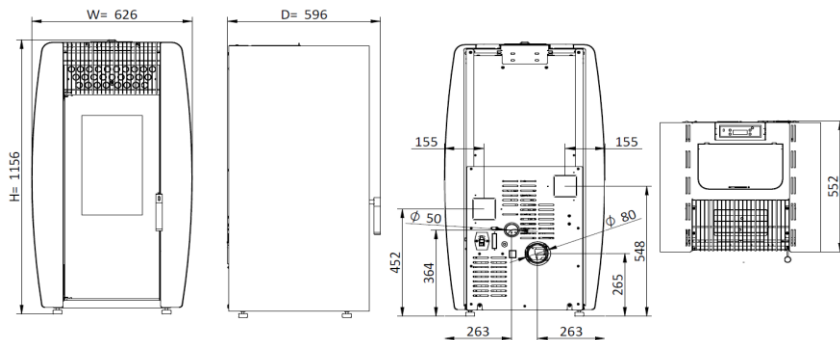
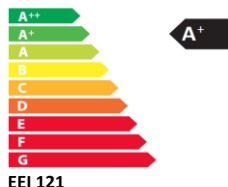
*** Valor recomendado para uma utilização óptima / Valor recomendado para el uso óptimo / Recommended value for optimum use / Valeur recommandée pour une utilisation optimale / Valore consigliato per un uso ottimale

Características técnicas / Datos técnicos / Technical characteristics / Caractéristiques techniques / Dati Tecnici
NORMA: EN 14785
RELATÓRIO: CEE-0201/19-1

Potência red-nom / Potencia red-nom / Min-Nom output power / Puissance red-nom / Potenza red-nom	3,9 - 11,9	(kW)
Rendimento Pot.red-Pot.nom / Rendimiento Pot.red-Pot.nom / Efficiency Red.power-Nom.power / Rendement Pui.red-Pui.nom / Rendimento Pot.rid-Pot.nom	96 - 92	(%)
Potência água / Potencia agua / Water output power / Puissance eau / Potenza acqua	n/a	(kW)
Temp. Fumos min.-máx. / Temp. Humos min.-máx. / Smoke temp. min.-máx. / Temp. Fumées min.-máx. / Temp. Fumi min.-máx.	53 - 125	(°C)
Emissões CO(13%O2) min.-máx. / Emisiones CO(13%O2) min.-máx. / Emissions CO(13%O2) min.-máx. / Émissions CO(13%O2) min.-máx. / Emissioni CO(13%O2) min.-máx.	0,045 - 0,016	(%)
CO2 min.-máx.	7,3 - 9,4	(%)
Partículas-OCG-NOX (13%O2) / Partículas-OCG-NOX (13%O2) / Particules-OCG-NOX (13%O2) / Particules-OCG-NOX (13%O2) / Particolato-OCG-NOX (13%O2)	12 - 6 - 154	(mg/Nm3)
Tiragem recomendada (máx. potência) / Tiro recomendado (máx. potencia) / Recommended draw (máx. power) / Tirage conseillé (máx. puissance) / Tiraggio consigliato (máx. potenza)	12 ***	(Pa)
Caudal mássico / Masa de humos / Mass flow / Débit massique / Flusso di massa	9,2	(g/s)
Tensão / Tensión / Voltage / Tension / Tensione	230	(V)
Frequência / Frecuencia / Frequency / Fréquence / Frecuenza	50	(Hz)
Potência elétrica nominal / Energía eléctrica nominal / Nominal electric power / Puissance électrique nominale / Energia elettrica nominal	167 (máx 362)	(W)
Consumo de pellets min.-máx. / Consumo de pellets min.-máx. / Pellet consumption min.-máx. / Consommation pellet min.-máx. / Consumo di pellet min.-máx.	0,9 - 2,7 **	(kg/h)
Capacidade do depósito / Capacidad del depósito / Tank capacity / Capacité du réservoir / Capacità serbatoio	30	(kg)
Autonomia à potência min.- máx. / Autonomia a la potencia min.-máx. / Autonomy to power min.-máx. / L'autonomie de puissance min.-máx. / L'autonomia di potenza min.-máx.	33,3 - 11,1 **	(H)
Diâmetro da chaminé / Diámetro de chimenea / Flue pipe / Diamètre de cheminée / Diametro del camino	80	(mm)
Entrada de ar da combustão / Entrada de aire para la combustión / Combustion air inlet / Entrée air pour la combustion / Ingresso aria per la combustione	50	(mm)
Volume aquecimento / Volumen de calefacción / Heating volume / Volume de chauffage / Volume di riscaldamento	269 *	(m3)
Caudal ventilador / Flujo del ventilador / Fan flow / Flux ventilateur / Flusso della ventola (25 Pa)	415	(m3/h)
Tipo de combustível / Tipo combustible / Type of fuel / Type combustible / Tipo combustibile	Pellet (EN 14961-2 A1) diam. 6 mm/ L 10-30 mm	-
Peso líquido / Peso neto / Net weight / Poids net / Peso netto	152	(kg)
Peso com embalagem / Peso com embalaje / Weight with packaging / Poids avec emballage / Peso con imballo	173	(kg)
Dimensões com embalagem (LxHxP) / Dimensiones con embalaje / Dimensions with packing / Dimensions avec l'emballage / Dimensioni con imballaggio	990 x 1440 x 640	(mm)
Volume água / Volumen de agua / Water volume / Volume d'eau / Volume di acqua	n/a	(L)
Pressão máx. / Pressione máx. / Pressure máx. / Pression máx. / Pressione máx.	n/a	(bar)
Distância mínima a materiais combustíveis (laterais/frente/topo) / Distancia mínima a materiales combustibles (laterales/frente/topo) / Minimum distance to combustible materials (side/front/top) / Distance minimale aux matériaux combustibles (côté/avanta/haut) / Distanza minima da materiali combustibili (lato/antieriore/sotto)	200 / 1500 / 1000	(mm)
Comprimento máx. de lenha / Longitud max. Leña / Length max. firewood / Longueur max. bois de chauffage / lunghezza max. legna	n/a	(mm)
Dimensão câmara de combustão (LxHxP) / Tamaño de la cámara de combustión / Combustion chamber size / Taille de la chambre de combustion / Dimensioni camera di combustione	276 x 415 x 170	(mm)
Nível sonoro ventilador - Ventilador auxiliar (máx.) / Nivel de sonido ventilador - Ventilador auxiliar (máx.) / Sound level fan - Auxiliary fan (máx.) / Niveau sonore ventilateur - Ventilateur auxiliaire (máx.) / Livello sonoro ventilatore - Ventola supplementare (máx.)	48 - 61	(dB)

Opções / Opciones / Options / Options / Opzioni
Conexão termostato WiFi / Conexión termostato Wi-Fi / Connection thermostat WiFi / Connexion thermostat WiFi / Collegamento termostato WiFi
Controlo Remoto / Control Remoto / Remote Control / Télécommande / Telecomando
Ventilador Auxiliar / Ventilador Auxiliar / Auxiliary fan / Ventilateur Auxiliaire / Ventola Supplementare
1x 135 m3/h (0 Pa) / 2x 135 m3/h (0 Pa)

* Valor que pode variar segundo o tipo de isolamento (Cálculo efectuado para 44 W/m3 ou 35 Kcal/h por m3) / El valor puede variar en función del tipo de aislamiento (El cálculo se realiza a 44 W/m3 o 35 Kcal/h per m3) / Value that could vary depending on the type of insulation (Calculation made to 44 W/m3 or 35 Kcal/h for m3) / La valeur peut varier en fonction du type d'isolation (Calcul fait à 44 W/m3 ou 35 Kcal/h par m3) / Il valore può variare a seconda del tipo di isolamento (Il calcolo fatto per 44 W/m3 o 35 Kcal/h per m3)

** Dados que podem variar segundo o tipo de pellet utilizado / Los datos pueden variar según el tipo de pellet utilizado / Data may vary according to the type of pellet used / Les données peuvent varier en fonction du type de pellets utilisé / Dati che possono variare a seconda del tipo di pellet usato

*** Valor recomendado para uma utilização óptima / Valor recomendado para el uso óptimo / Recommended value for optimum use / Valeur recommandée pour une utilisation optimale / Valore consigliato per un uso ottimale

Dimensões Caixa / Dimensiones de la Caja / Box Dimensions / Dimensioni Boîte / Scatola di Dimensioni

Equipamento / Equipamiento / Equipment / Équipement / Attrezzatura - 660 x 560 x 1175 (mm)

Capas / Cubiertas / Covers / Couvertres / Coperture - 1260 x 580 x 170 (mm)

Distâncias de Segurança / Distancias de Seguridad / Safety distances / Les distances de sécurité / Distanze di sicurezza

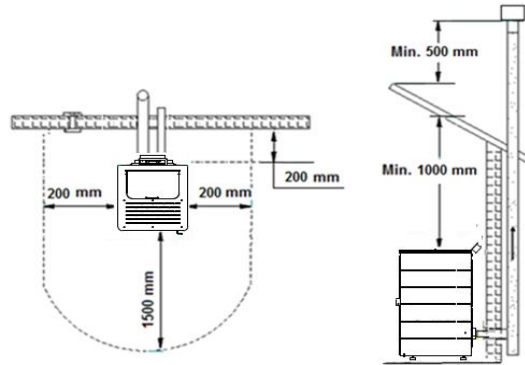

Cores disponíveis / Colores disponibles / Available colors / Couleurs disponibles / Colori disponibili :

- i) Branco / Blanco / White / Blanc / Bianco
- ii) Carvalho / Roble / Oak / Chêne / Quercia



i)

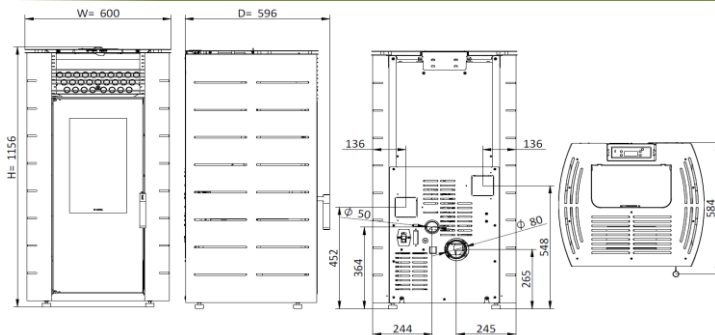

ii)

Características técnicas / Datos técnicos / Technical characteristics / Caractéristiques techniques / Dati Tecnici

NORMA: EN 14785	RELATÓRIO: CEE-0201/19-1	CE
------------------------	---------------------------------	-----------

Potência red-nom / Potencia red-nom / Min-Nom output power / Puissance red-nom / Potenza red-nom	3,9 - 11,9	(kW)
Rendimento Pot.red-Pot.nom / Rendimiento Pot.red-Pot.nom / Efficiency Red.power-Nom.power / Rendement Pui.red-Pui.nom / Rendimento Pot.rid-Pot.nom	96 - 92	(%)
Potência água / Potencia agua / Water output power / Puissance eau / Potenza acqua	n/a	(kW)
Temp. Fumos min.-máx. / Temp. Humos min.-máx. / Smoke temp. min.-máx. / Temp. Fumées min.-máx. / Temp. Fumi min.-máx.	53 - 125	(°C)
Emissões CO(13%O2) min.-máx. / Emisiones CO(13%O2) min.-máx. / Emissions CO(13%O2) min.-máx. / Émissions CO(13%O2) min.-máx. / Emissioni CO(13%O2) min.-máx.	0,045 - 0,016	(%)
CO2 min.-máx.	7,3 - 9,4	(%)
Partículas-OCG-NOX (13%O2) / Partículas-OCG-NOX (13%O2) / Particules-OCG-NOX (13%O2) / Particulas-OCG-NOX (13%O2) / Particolato-OCG-NOX (13%O2)	12 - 6 - 154	(mg/Nm3)
Tiragem recomendada (máx. potência) / Tiro recomendado (máx. potencia) / Recommended draw (máx. power) / Tirage conseillé (máx. puissance) / Tiraggio consigliato (máx. potenza)	12 ***	(Pa)
Caudal mássico / Masa de humos / Mass flow / Débit massique / Flusso di massa	9,2	(g/s)
Tensão / Tensión / Voltage / Tension / Tensione	230	(V)
Frequência / Frecuencia / Frequency / Fréquence / Frecuenza	50	(Hz)
Potência eléctrica nominal / Energía eléctrica nominal / Nominal electric power / Puissance électrique nominale / Energia elettrica nominal	167 (máx 362)	(W)
Consumo de pellets min.-máx. / Consumo de pellets min.-máx. / Pellet consumption min.-máx. / Consommation pellet min.-máx. / Consumo di pellet min.-máx.	0,9 - 2,7 **	(kg/h)
Capacidade do depósito / Capacidad del depósito / Tank capacity / Capacité du réservoir / Capacità serbatoio	30	(kg)
Autonomia à potência min.- máx. / Autonomia a la potencia min.-máx. / Autonomy to power min.-máx. / L'autonomie de puissance min.-máx. / L'autonomia di potenza min.máx.	33,3 - 11,1 **	(H)
Diâmetro da chaminé / Diámetro de chimenea / Flue pipe / Diamètre de cheminée / Diametro del camino	80	(mm)
Entrada de ar da combustão / Entrada de aire para la combustión / Combustion air inlet / Entrée air pour la combustion / Ingresso aria per la combustione	50	(mm)
Volume aquecimento / Volumen de calefacción / Heating volume / Volume de chauffage / Volume di riscaldamento	269 *	(m3)
Caudal ventilador / Flujo del ventilador / Fan flow / Flux ventilateur / Flusso della ventola (25 Pa)	415	(m3/h)
Tipo de combustível / Tipo combustible / Type of fuel / Type combustible / Tipo combustibile	Pellet (EN 14961-2 A1) diam. 6 mm/ L 10-30 mm	-
Peso líquido / Peso neto / Net weight / Poids net / Peso netto	143	(kg)
Peso com embalagem / Peso com embalaje / Weight with packaging / Poids avec emballage / Peso con imballo	164	(kg)
Dimensões com embalagem (LxHxP) / Dimensiones con embalaje / Dimensions with packing / Dimensions avec l'emballage / Dimensioni con imballaggio	990 x 1440 x 640	(mm)
Volume água / Volumen de agua / Water volume / Volume d'eau / Volume di acqua	n/a	(L)
Pressão máx. / Pressione máx. / Pressure máx. / Pression máx. / Pressione máx.	n/a	(bar)
Distância mínima a materiais combustíveis (laterais/frente/topo) / Distancia mínima a materiales combustibles (laterales/frente/topo) / Minimum distance to combustible materials (side/front/top) / Distance minimale aux matériaux combustibles (côté/avanta/haut) / Distanza minima da materiali combustibili (lato/anteriore/sotto)	200 / 1500 / 1000	(mm)
Comprimento máx. de lenha / Longitud max. Leña / Length max. Firewood / Longueur max. bois de chauffage / lunghezza max. legna	n/a	(mm)
Dimensão câmara de combustão (LxHxP) / Tamaño de la cámara de combustión / Combustion chamber size / Taille de la chambre de combustion / Dimensioni camera di combustione	276 x 415 x 170	(mm)
Nível sonoro ventilador - Ventilador auxiliar (máx.) / Nivel de sonido ventilador - Ventilador auxiliar (máx.) / Sound level fan - Auxiliary fan (máx.) / Niveau sonore ventilateur - Ventilateur auxiliaire (máx.) / Livello sonoro ventilatore - Ventola supplementare (máx.)	48 - 61	(dB)

Opções / Opciones / Options / Options / Opzioni
Conexão termostato WiFi / Conexión termostato Wi-Fi / Connection thermostat WiFi / Connexion thermostat WiFi / Collegamento termostato WiFi
Controlo Remoto / Control Remoto / Remote Control / Télécommande / Telecomando
Ventilador Auxiliar / Ventilador Auxiliar / Auxiliary fan / Ventilateur Auxiliaire / Ventola Supplementare
1x 135 m3/h (0 Pa) / 2x 135 m3/h (0 Pa)

* Valor que pode variar segundo o tipo de isolamento (Calculo efectuado para 44 W/m3 ou 35 Kcal/h por m3) / El valor puede variar en función del tipo de aislamiento (El cálculo se realiza a 44 W/m3 o 35 Kcal/h per m3) / Value that could vary depending on the type of insulation (Calculation made to 44 W/m3 or 35 Kcal/h for m3) / La valeur peut varier en fonction du type d'isolation (Calcul fait à 44 W/m3 ou 35 Kcal/h par m3) / Il valore può variare a seconda del tipo di isolamento (Il calcolo fatto per 44 W/m3 o 35 Kcal/h per m3)

** Dados que podem variar segundo o tipo de pellet utilizado / Los datos pueden variar según el tipo de pellet utilizado / Data may vary according to the type of pellet used / Les données peuvent varier en fonction du type de pellets utilisé / Dati che possono variare a seconda del tipo di pellet usato

*** Valor recomendado para uma utilização óptima / Valor recomendado para el uso óptimo / Recommended value for optimum use / Valeur recommandée pour une utilisation optimale / Valore consigliato per un uso ottimale

Dimensões Caixa / Dimensiones de la Caja / Box Dimensions / Dimensions Boîte / Scatola di Dimensioni

Equipamento / Equipamiento / Equipment / Équipement / Attrezzatura - 660 x 560 x 1175 (mm)

Capas / Cubiertas / Covers / Couvertres / Coperture - 1260 x 580 x 170 (mm)

Distâncias de Segurança / Distancias de Seguridad / Safety distances / Les distances de sécurité / Distanze di sicurezza

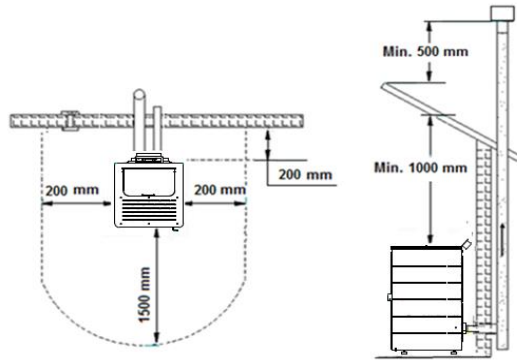

Cores disponíveis / Colores disponibles / Available colors / Couleurs disponibles / Colori disponibili :

- i) Branco / Blanco / White / Blanc / Bianco
- ii) Bordeaux / Burdeos / Bordeaux / Bordeaux / Bordò



i)

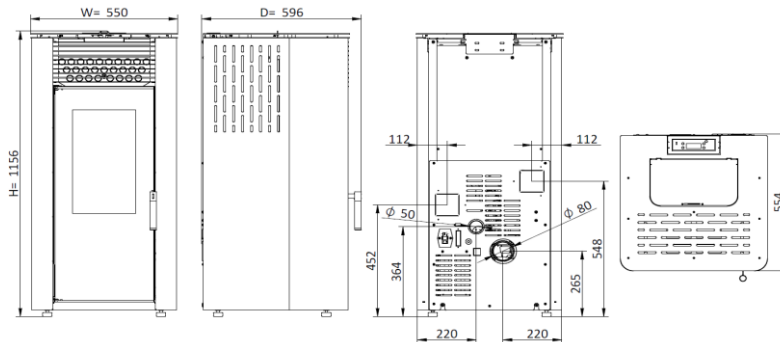

ii)

Características técnicas / Datos técnicos / Technical characteristics / Caractéristiques techniques / Dati Tecnici
NORMA: EN 14785
RELATÓRIO: CEE-0201/19-1

Potência red-nom / Potencia red-nom / Min-Nom output power / Puissance red-nom / Potenza red-nom	3,9 - 11,9	(kW)
Rendimento Pot.red-Pot.nom / Rendimiento Pot.red-Pot.nom / Efficiency Red.power-Nom.power / Rendement Pui.red-Pui.nom / Rendimento Pot.rid-Pot.nom	96 - 92	(%)
Potência água / Potencia agua / Water output power / Puissance eau / Potenza acqua	n/a	(kW)
Temp. Fumos min.-máx. / Temp. Humos min.-máx. / Smoke temp. min.-máx. / Temp. Fumées min.-máx. / Temp. Fumi min.-máx.	53 - 125	(°C)
Emissões CO(13%O2) min.-máx. / Emisiones CO(13%O2) min.-máx. / Emissions CO(13%O2) min.-máx. / Émissions CO(13%O2) min.-máx. / Emissioni CO(13%O2) min.-máx.	0,045 - 0,016	(%)
CO2 min.-máx.	7,3 - 9,4	(%)
Partículas-OCG-NOX (13%O2) / Partículas-OCG-NOX (13%O2) / Particles-OCG-NOX (13%O2) / Particules-OCG-NOX (13%O2) / Particolato-OCG-NOX (13%O2)	12 - 6 - 154	(mg/Nm3)
Tiragem recomendada (máx. potência) / Tiro recomendado (máx. potencia) / Recommended draw (máx. power) / Tirage conseillé (máx. puissance) / Tiraggio consigliato (máx. potenza)	12 ***	(Pa)
Caudal mássico / Masa de humos / Mass flow / Débit massique / Flusso di massa	9,2	(g/s)
Tensão / Tensión / Voltage / Tension / Tensione	230	(V)
Frequência / Frecuencia / Frequency / Fréquence / Frecuenza	50	(Hz)
Potência elétrica nominal / Energía eléctrica nominal / Nominal electric power / Puissance électrique nominale / Energia elettrica nominal	167 (máx 362)	(W)
Consumo de pellets min.-máx. / Consumo de pellets min.-máx. / Pellet consumption min.-máx. / Consommation pellet min.-máx. / Consumo di pellet min.-máx.	0,9 - 2,7 **	(kg/h)
Capacidade do depósito / Capacidad del depósito / Tank capacity / Capacité du réservoir / Capacità serbatoio	30	(kg)
Autonomia à potência min.- máx. / Autonomia a la potencia min.-máx. / Autonomy to power min.-máx. / L'autonomie de puissance min.-máx. / L'autonomia di potenza min.-máx.	33,3 - 11,1 **	(H)
Diâmetro da chaminé / Diámetro de chimenea / Flue pipe / Diamètre de cheminée / Diametro del camino	80	(mm)
Entrada de ar da combustão / Entrada de aire para la combustión / Combustion air inlet / Entrée air pour la combustion / Ingresso aria per la combustione	50	(mm)
Volume aquecimento / Volumen de calefacción / Heating volume / Volume de chauffage / Volume di riscaldamento	269 *	(m3)
Caudal ventilador / Flujo del ventilador / Fan flow / Flux ventilateur / Flusso della ventola (25 Pa)	415	(m3/h)
Tipo de combustível / Tipo combustible / Type of fuel / Type combustible / Tipo combustibile	Pellet (EN 14961-2 A1) diam. 6 mm/ L 10-30 mm	-
Peso líquido / Peso neto / Net weight / Poids net / Peso netto	145	(kg)
Peso com embalagem / Peso com embalaje / Weight with packaging / Poids avec emballage / Peso con imballo	166	(kg)
Dimensões com embalagem (LxHxP) / Dimensiones con embalaje / Dimensions with packing / Dimensions avec l'emballage / Dimensioni con imballaggio	990 x 1440 x 640	(mm)
Volume água / Volumen de agua / Water volume / Volume d'eau / Volume di acqua	n/a	(L)
Pressão máx. / Pressione máx. / Pressure máx. / Pression máx. / Pressione máx.	n/a	(bar)
Distância mínima a materiais combustíveis (laterais/frente/topo) / Distancia mínima a materiales combustibles (laterales/frente/topo) / Minimum distance to combustible materials (side/front/top) / Distance minimale aux matériaux combustibles (côté/avanta/haut) / Distanza minima da materiali combustibili (lato/antieriore/sotto)	200 / 1500 / 1000	(mm)
Comprimento máx. de lenha / Longitud max. Leña / Length max. firewood / Longueur max. bois de chauffage / lunghezza max. legna	n/a	(mm)
Dimensão câmara de combustão (LxHxP) / Tamaño de la cámara de combustión / Combustion chamber size / Taille de la chambre de combustion / Dimensioni camera di combustione	276 x 415 x 170	(mm)
Nível sonoro ventilador - Ventilador auxiliar (máx.) / Nivel de sonido ventilador - Ventilador auxiliar (máx.) / Sound level fan - Auxiliary fan (máx.) / Niveau sonore ventilateur - Ventilateur auxiliaire (máx.) / Livello sonoro ventilatore - Ventola supplementare (máx.)	48 - 61	(dB)

Opções / Opciones / Options / Options / Opzioni
Conexão termostato WiFi / Conexión termostato Wi-Fi / Connection thermostat WiFi / Connexion thermostat WiFi / Collegamento termostato WiFi
Controlo Remoto / Control Remoto / Remote Control / Télécommande / Telecomando
Ventilador Auxiliar / Ventilador Auxiliar / Auxiliary fan / Ventilateur Auxiliaire / Ventola Supplementare
1x 135 m3/h (0 Pa) / 2x 135 m3/h (0 Pa)

* Valor que pode variar segundo o tipo de isolamento (Cálculo efectuado para 44 W/m3 ou 35 Kcal/h por m3)/ El valor puede variar en función del tipo de aislamiento (El cálculo se realiza a 44 W/m3 o 35 Kcal/h per m3)/ Value that could vary depending on the type of insulation (Calculation made to 44 W/m3 or 35 Kcal/h for m3)/ La valeur peut varier en fonction du type d'isolation (Calcul fait à 44 W/m3 o 35 Kcal/h par m3)/ Il valore può variare a seconda del tipo di isolamento (Il calcolo fatto per 44 W/m3 o 35 Kcal/h per m3)

** Dados que podem variar segundo o tipo de pellet utilizado/ Los datos pueden variar según el tipo de pellet utilizado/ Data may vary according to the type of pellet used/ Les données peuvent varier en fonction du type de pellets utilisé/ Dati che possono variare a seconda del tipo di pellet usato

*** Valor recomendado para uma utilização ótima/ Valor recomendado para el uso óptimo/ Recommended value for optimum use/ Valeur recommandée pour une utilisation optimale/ Valore consigliato per un uso ottimale

Dimensões Caixa / Dimensiones de la Caja / Box Dimensions / Dimensions Boîte / Scatola di Dimensioni

Equipamento / Equipamiento / Equipment / Équipement / Attrezzatura - 660 x 560 x 1175 (mm)

Capas / Cubiertas / Covers / Couvertres / Coperture - 1092 x 582 x 164 (mm)

Distâncias de Segurança / Distancias de Seguridad / Safety distances / Les distances de sécurité / Distanze di sicurezza

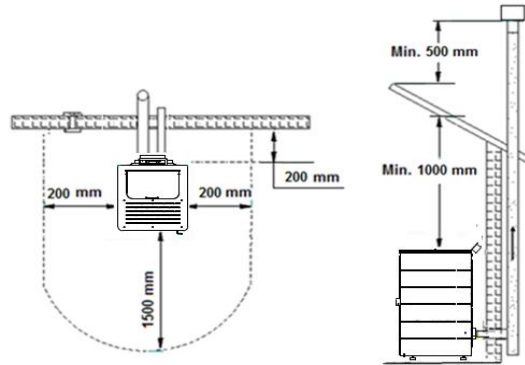

Cores disponíveis / Colores disponibles / Available colors / Couleurs disponibles / Colori disponibili :

- i) Branco / Blanco / White / Blanc / Bianco
- ii) Carvalho / Roble / Oak / Chêne / Quercia



i)

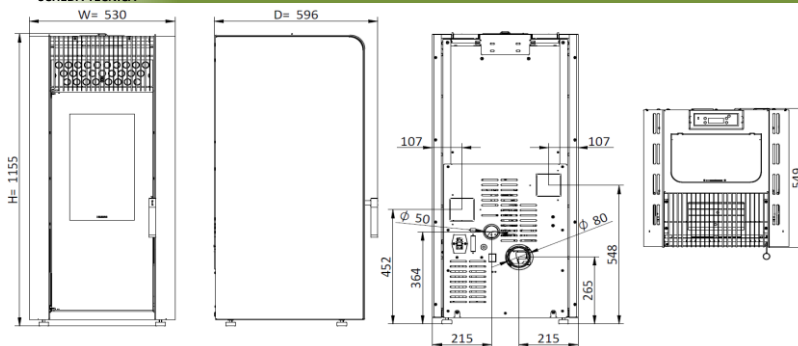
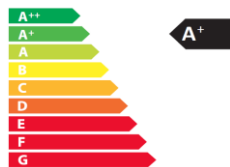

ii)

Características técnicas / Datos técnicos / Technical characteristics / Caractéristiques techniques / Dati Tecnici
NORMA: EN 14785
RELATÓRIO: CEE-0201/19-1

Potência red-nom / Potencia red-nom / Min-Nom output power / Puissance red-nom / Potenza red-nom	3,9 - 11,9	(kW)
Rendimento Pot.red-Pot.nom / Rendimiento Pot.red-Pot.nom / Efficiency Red.power-Nom.power / Rendement Pui.red-Pui.nom / Rendimento Pot.rid-Pot.nom	96 - 92	(%)
Potência água / Potencia agua / Water output power / Puissance eau / Potenza acqua	n/a	(kW)
Temp. Fumos min.-máx. / Temp. Humos min.-máx. / Smoke temp. min.-máx. / Temp. Fumées min.-máx. / Temp. Fumi min.-máx.	53 - 125	(°C)
Emissões CO(13%O2) min.-máx. / Emisiones CO(13%O2) min.-máx. / Emissions CO(13%O2) min.-máx. / Émissions CO(13%O2) min.-máx. / Emissioni CO(13%O2) min.-máx.	0,045 - 0,016	(%)
CO2 min.-máx.	7,3 - 9,4	(%)
Partículas-OCG-NOX (13%O2) / Partículas-OCG-NOX (13%O2) / Particules-OCG-NOX (13%O2) / Particules-OCG-NOX (13%O2) / Particolato-OCG-NOX (13%O2)	12 - 6 - 154	(mg/Nm3)
Tiragem recomendada (máx. potência) / Tiro recomendado (máx. potencia) / Recommended draw (máx. power) / Tirage conseillé (máx. puissance) / Tiraggio consigliato (máx. potenza)	12 ***	(Pa)
Caudal mássico / Masa de humos / Mass flow / Débit massique / Flusso di massa	9,2	(g/s)
Tensão / Tensión / Voltage / Tension / Tensione	230	(V)
Frequência / Frecuencia / Frequency / Fréquence / Freqwenza	50	(Hz)
Potência elétrica nominal / Energía eléctrica nominal / Nominal electric power / Puissance électrique nominale / Energia elettrica nominal	167 (máx 362)	(W)
Consumo de pellets min.-máx. / Consumo de pellets min.-máx. / Pellet consumption min.-máx. / Consommation pellet min.-máx. / Consumo di pellet min.-máx.	0,9 - 2,7 **	(kg/h)
Capacidade do depósito / Capacidad del depósito / Tank capacity / Capacité du réservoir / Capacità serbatoio	30	(kg)
Autonomia à potência min.- máx. / Autonomia a la potencia min.-máx. / Autonomy to power min.-máx. / L'autonomie de puissance min.-máx. / L'autonomia di potenza min.-máx.	33,3 - 11,1 **	(H)
Diâmetro da chaminé / Diámetro de chimenea / Flue pipe / Diamètre de cheminée / Diametro del camino	80	(mm)
Entrada de ar da combustão / Entrada de aire para la combustión / Combustion air inlet / Entrée air pour la combustion / Ingresso aria per la combustione	50	(mm)
Volume aquecimento / Volumen de calefacción / Heating volume / Volume de chauffage / Volume di riscaldamento	269 *	(m3)
Caudal ventilador / Flujo del ventilador / Fan flow / Flux ventilateur / Flusso della ventola (25 Pa)	415	(m3/h)
Tipo de combustível / Tipo combustible / Type of fuel / Type combustible / Tipo combustibile	Pellet (EN 14961-2 A1) diam. 6 mm / L 10-30 mm	-
Peso líquido / Peso neto / Net weight / Poids net / Peso netto	152	(kg)
Peso com embalagem / Peso com embalaje / Weight with packaging / Poids avec emballage / Peso con imballo	173	(kg)
Dimensões com embalagem (LxHxP) / Dimensiones con embalaje / Dimensions with packing / Dimensions avec l'emballage / Dimensioni con imballaggio	990 x 1440 x 640	(mm)
Volume água / Volumen de agua / Water volume / Volume d'eau / Volume di acqua	n/a	(L)
Pressão máx. / Pressione máx. / Pressure máx. / Pression máx. / Pressione máx.	n/a	(bar)
Distância mínima a materiais combustíveis (laterais/frente/topo) / Distancia mínima a materiales combustibles (laterales/frente/topo) / Minimum distance to combustible materials (side/front/top) / Distance minimale aux matériaux combustibles (côté/avanta/haut) / Distanza minima da materiali combustibili (lato/antieriore/sotto)	200 / 1500 / 1000	(mm)
Comprimento máx. de lenha / Longitud max. Leña / Length max. firewood / Longueur max. bois de chauffage / lunghezza max. legna	n/a	(mm)
Dimensão câmara de combustão (LxHxP) / Tamaño de la cámara de combustión / Combustion chamber size / Taille de la chambre de combustion / Dimensioni camera di combustione	276 x 415 x 170	(mm)
Nível sonoro ventilador - Ventilador auxiliar (máx.) / Nivel de sonido ventilador - Ventilador auxiliar (máx.) / Sound level fan - Auxiliary fan (máx.) / Niveau sonore ventilateur - Ventilateur auxiliaire (máx.) / Livello sonoro ventilatore - Ventola supplementare (máx.)	48 - 61	(dB)

Opções / Opciones / Options / Options / Opzioni
Conexão termostato WiFi / Conexión termostato Wi-Fi / Connection thermostat WiFi / Connexion thermostat WiFi / Collegamento termostato WiFi
Controlo Remoto / Control Remoto / Remote Control / Télécommande / Telecomando
Ventilador Auxiliar / Ventilador Auxiliar / Auxiliary fan / Ventilateur Auxiliaire / Ventola Supplementare
1x 135 m3/h (0 Pa) / 2x 135 m3/h (0 Pa)

* Valor que pode variar segundo o tipo de isolamento (Cálculo efectuado para 44 W/m3 ou 35 Kcal/h por m3) / El valor puede variar en función del tipo de aislamiento (El cálculo se realiza a 44 W/m3 o 35 Kcal/h per m3) / Value that could vary depending on the type of insulation (Calculation made to 44 W/m3 or 35 Kcal/h for m3) / La valeur peut varier en fonction du type d'isolation (Calcul fait à 44 W/m3 ou 35 Kcal/h par m3) / Il valore può variare a seconda del tipo di isolamento (Il calcolo fatto per 44 W/m3 o 35 Kcal/h per m3)

** Dados que podem variar segundo o tipo de pellet utilizado / Los datos pueden variar según el tipo de pellet utilizado / Data may vary according to the type of pellet used / Les données peuvent varier en fonction du type de pellets utilisé / Dati che possono variare a seconda del tipo di pellet usato

*** Valor recomendado para uma utilização óptima / Valor recomendado para el uso óptimo / Recommended value for optimum use / Valeur recommandée pour une utilisation optimale / Valore consigliato per un uso ottimale

Dimensões Caixa / Dimensiones de la Caja / Box Dimensions / Dimensions Boîte / Scatola di Dimensioni

Equipamento / Equipamiento / Equipment / Équipement / Attrezzatura - 660 x 560 x 1175 (mm)

Capas / Cubiertas / Covers / Couvertres / Coperture - 1260 x 580 x 170 (mm)

Distâncias de Segurança / Distancias de Seguridad / Safety distances / Les distances de sécurité / Distanze di sicurezza

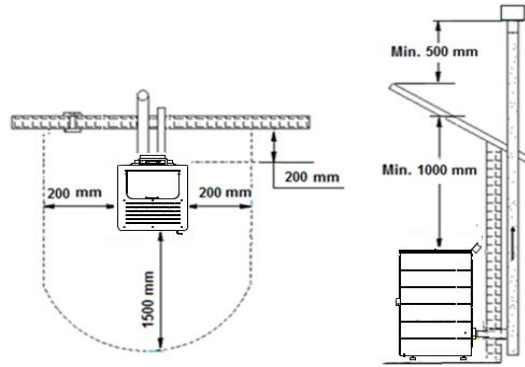

Cores disponíveis / Colores disponibles / Available colors / Couleurs disponibles / Colori disponibili :

- i) Branco e Preto / Blanco y Negro / White and Black / Blanc et Noir / Bianco e Nero
- ii) Preto / Negro / Black / Noir / Nero



i)



ii)

PELLETS LOCAL HEATING

STOVES WITH OPTIONAL PIPED VENTILATION



Pellet stoves are an excellent option if you are looking for a local heating solution that can heat more than one room, in an economical and practical way. The stove is installed in one room of the house and the distribution to the other rooms is done through hot air tubes, allowing a quick and homogeneous heating. You can find in this catalog several aesthetics for this type of equipment, from hall stoves to round stoves or more conventional models.

When installing hot air distribution pipes, it is advisable to place the equipment in a position that allows the hot air to diffuse through the place where it is inserted, but also in a direction that helps it leave the room.

The piping hot air outlet grilles should not be too far from the equipment in order to minimize efficiency losses.

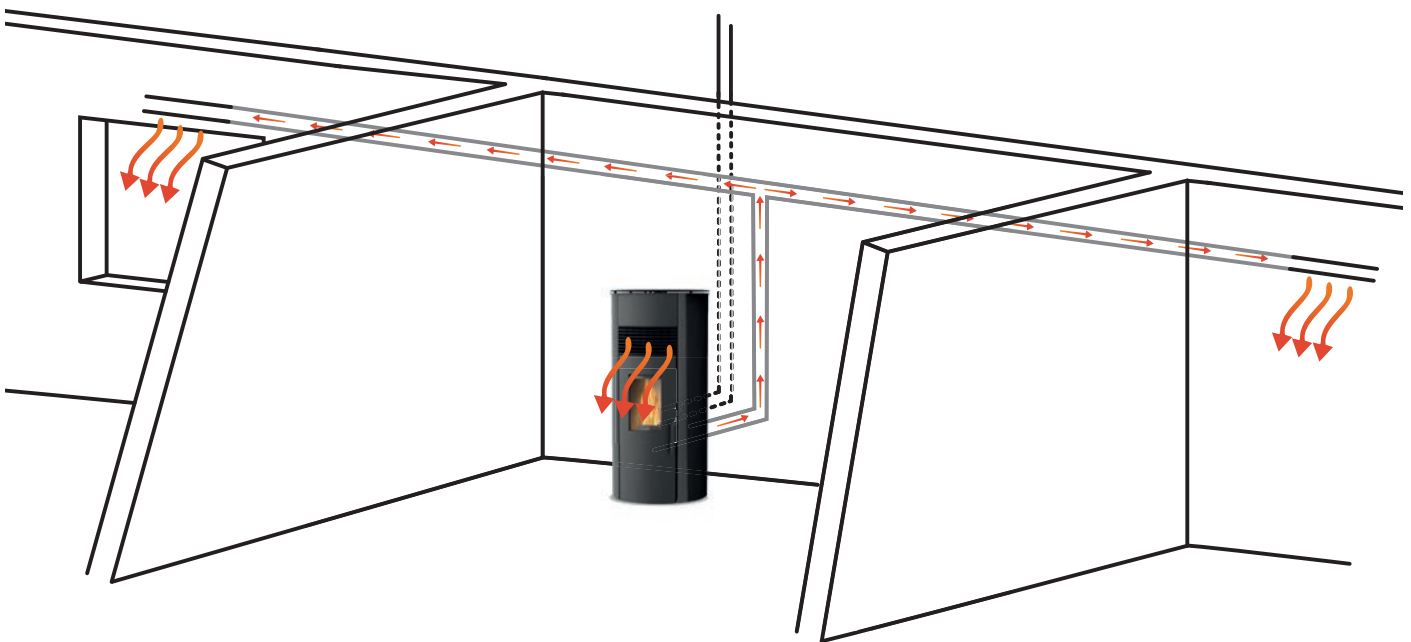

PELLETS LOCAL HEATING

STOVES WITH OPTIONAL PIPED VENTILATION



K2 COLLECTION 12 KW A+

HOPPER AUTONOMY MIN-MAX (h)	11,1 - 33,3
HOPPER CAPACITY (kg)	30
REDUCED / NOMINAL POWER (kW)	3,9-11,9
REDUCED / NOMINAL EFFICIENCY (%)	96,0-92,0
HEATING VOLUME (m ³)	269
CONSUMPTION (kg/h)	0,9-2,7
CHIMNEY DIAMETER (mm)	80
HEIGHT (mm)	1156
WIDTH (mm)	600
DEPTH (mm)	596
WEIGHT (kg)	143
MAXIMUM NOISE LEVEL (dB)	61

COLOURS



WHITE BORDEAUX



K2 COLLECTION 12 KW - Glass Door A+

HOPPER AUTONOMY MIN-MAX (h)	11,1 - 33,3
HOPPER CAPACITY (kg)	30
REDUCED / NOMINAL POWER (kW)	3,9-11,9
REDUCED / NOMINAL EFFICIENCY (%)	96,0-92,0
HEATING VOLUME (m ³)	269
CONSUMPTION (kg/h)	0,9-2,7
CHIMNEY DIAMETER (mm)	80
HEIGHT (mm)	1156
WIDTH (mm)	600
DEPTH (mm)	596
WEIGHT (kg)	143
MAXIMUM NOISE LEVEL (dB)	61

COLOURS



WHITE BORDEAUX



FUJI COLLECTION 12 KW A+

HOPPER AUTONOMY MIN-MAX (h)	11,1 - 33,3
HOPPER CAPACITY (kg)	30
REDUCED / NOMINAL POWER (kW)	3,9-11,9
REDUCED / NOMINAL EFFICIENCY (%)	96,0-92,0
HEATING VOLUME (m ³)	269
CONSUMPTION (kg/h)	0,9-2,7
CHIMNEY DIAMETER (mm)	80
HEIGHT (mm)	1156
WIDTH (mm)	550
DEPTH (mm)	596
WEIGHT (kg)	145
MAXIMUM NOISE LEVEL (dB)	61

COLOURS



WHITE

SPECIAL COLOURS



OAK



FUJI COLLECTION 12 KW Glass Door A+

HOPPER AUTONOMY MIN-MAX (h)	11,1 - 33,3
HOPPER CAPACITY (kg)	30
REDUCED / NOMINAL POWER (kW)	3,9-11,9
REDUCED / NOMINAL EFFICIENCY (%)	96,0-92,0
HEATING VOLUME (m ³)	269
CONSUMPTION (kg/h)	0,9-2,7
CHIMNEY DIAMETER (mm)	80
HEIGHT (mm)	1156
WIDTH (mm)	550
DEPTH (mm)	596
WEIGHT (kg)	145
MAXIMUM NOISE LEVEL (dB)	61

COLOURS



WHITE

SPECIAL COLOURS



OAK



PINE COLLECTION 12 KW A+

HOPPER AUTONOMY MIN-MAX (h)	11,1 - 33,3
HOPPER CAPACITY (kg)	30
REDUCED / NOMINAL POWER (kW)	3,9-11,9
REDUCED / NOMINAL EFFICIENCY (%)	96,0-92,0
HEATING VOLUME (m ³)	269
CONSUMPTION (kg/h)	0,9-2,7
CHIMNEY DIAMETER (mm)	80
HEIGHT (mm)	1156
WIDTH (mm)	626
DEPTH (mm)	596
WEIGHT (kg)	152
MAXIMUM NOISE LEVEL (dB)	61

COLOURS



WHITE

SPECIAL COLOURS



OAK



PINE COLLECTION 12 KW Glass Door A+

HOPPER AUTONOMY MIN-MAX (h)	11,1 - 33,3
HOPPER CAPACITY (kg)	30
REDUCED / NOMINAL POWER (kW)	3,9-11,9
REDUCED / NOMINAL EFFICIENCY (%)	96,0-92,0
HEATING VOLUME (m ³)	269
CONSUMPTION (kg/h)	0,9-2,7
CHIMNEY DIAMETER (mm)	80
HEIGHT (mm)	1156
WIDTH (mm)	626
DEPTH (mm)	596
WEIGHT (kg)	152
MAXIMUM NOISE LEVEL (dB)	61

COLOURS



WHITE

SPECIAL COLOURS



OAK

STOVES WITH OPTIONAL PIPED VENTILATION

ASPEN COLLECTION 12 KW **A+**



HOPPER AUTONOMY MIN-MAX (h)	11,1 - 33,3
HOPPER CAPACITY (kg)	30
REDUCED / NOMINAL POWER (kW)	3,9-11,9
REDUCED / NOMINAL EFFICIENCY (%)	96,0-92,0
HEATING VOLUME (m ³)	269
CONSUMPTION (kg/h)	0,9-2,7
CHIMNEY DIAMETER (mm)	80
HEIGHT (mm)	1156
WIDTH (mm)	530
DEPTH (mm)	596
WEIGHT (kg)	152
MAXIMUM NOISE LEVEL (dB)	61



COLOURS

SPECIAL COLOURS



BLACK AND WHITE



BLACK

ASPEN COLLECTION 12 KW **A+** Glass Door



HOPPER AUTONOMY MIN-MAX (h)	11,1 - 33,3
HOPPER CAPACITY (kg)	30
REDUCED / NOMINAL POWER (kW)	3,9-11,9
REDUCED / NOMINAL EFFICIENCY (%)	96,0-92,0
HEATING VOLUME (m ³)	269
CONSUMPTION (kg/h)	0,9-2,7
CHIMNEY DIAMETER (mm)	80
HEIGHT (mm)	1156
WIDTH (mm)	530
DEPTH (mm)	596
WEIGHT (kg)	152
MAXIMUM NOISE LEVEL (dB)	61



COLOURS

SPECIAL COLOURS



BLACK AND WHITE



BLACK

OPTIONALS STOVES (PELLETS)



Description

K600/12 kW ducted ventilation kit
* kit includes fan with a flow rate 135m³/h, connection wiring and rear air outlet
** this equipment allows the use of 2 additional fans



Description

Nevada Wall Suspension Kit



Description

Nevada Ventilation Kit



Description

Amazon Piped Ventilation Kit



Description

Wi-Fi Kit + (Columbus)



Description

Wi-Fi Kit

Алматы (7273)495-231
Ангарск (3955)60-70-56
Архангельск (8182)63-90-72
Астрахань (8512)99-46-04
Барнаул (3852)73-04-60
Белгород (4722)40-23-64
Благовещенск (4162)22-76-07
Брянск (4832)59-03-52
Владивосток (423)249-28-31
Владикавказ (8672)28-90-48
Владимир (4922)49-43-18
Волгоград (844)278-03-48
Вологда (8172)26-41-59
Воронеж (473)204-51-73
Екатеринбург (343)384-55-89

Иваново (4932)77-34-06
Ижевск (3412)26-03-58
Иркутск (395)279-98-46
Казань (843)206-01-48
Калининград (4012)72-03-81
Калуга (4842)92-23-67
Кемерово (3842)65-04-62
Киров (8332)68-02-04
Коломна (4966)23-41-49
Кострома (4942)77-07-48
Краснодар (861)203-40-90
Красноярск (391)204-63-61
Курск (4712)77-13-04
Курган (3522)50-90-47
Липецк (4742)52-20-81

Магнитогорск (3519)55-03-13
Москва (495)268-04-70
Мурманск (8152)59-64-93
Набережные Челны (8552)20-53-41
Нижний Новгород (831)429-08-12
Новокузнецк (3843)20-46-81
Ноябрьск (3496)41-32-12
Новосибирск (383)227-86-73
Омск (3812)21-46-40
Орел (4862)44-53-42
Оренбург (3532)37-68-04
Пенза (8412)22-31-16
Петрозаводск (8142)55-98-37
Псков (8112)59-10-37

Пермь (342)205-81-47
Ростов-на-Дону (863)308-18-15
Рязань (4912)46-61-64
Самара (846)206-03-16
Саранск (8342)22-96-24
Санкт-Петербург (812)309-46-40
Саратов (845)249-38-78
Севастополь (8692)22-31-93
Симферополь (3652)67-13-56
Смоленск (4812)29-41-54
Сочи (862)225-72-31
Ставрополь (8652)20-65-13
Сургут (3462)77-98-35
Сыктывкар (8212)25-95-17
Тамбов (4752)50-40-97

Тверь (4822)63-31-35
Тольятти (8482)63-91-07
Томск (3822)98-41-53
Тула (4872)33-79-87
Тюмень (3452)66-21-18
Ульяновск (8422)24-23-59
Улан-Удэ (3012)59-97-51
Уфа (347)229-48-12
Хабаровск (4212)92-98-04
Чебоксары (8352)28-53-07
Челябинск (351)202-03-61
Череповец (8202)49-02-64
Чита (3022)38-34-83
Якутск (4112)23-90-97
Ярославль (4852)69-52-93

Россия +7(495)268-04-70

Казахстан +7(7172)727-132

Киргизия +996(312)96-26-47

www.solzaima.nt-rt.ru | | sax@nt-rt.ru